

IFBB SET-UP SHEET

NAME: _____
 DATE: _____
 TRACK: _____
 EVENT: _____

TRACK			
TRACK SIZE	<input type="checkbox"/> SMALL	<input type="checkbox"/> MEDIUM	<input type="checkbox"/> LARGE
GRIP LEVEL	<input type="checkbox"/> LOW	<input type="checkbox"/> MEDIUM	<input type="checkbox"/> HIGH
TRACK CONDITION	<input type="checkbox"/> SMOOTH	<input type="checkbox"/> GROOVED	<input type="checkbox"/> BUMPY
	<input type="checkbox"/> WET	<input type="checkbox"/> DUSTY	<input type="checkbox"/> LOAMY

COMMENTS

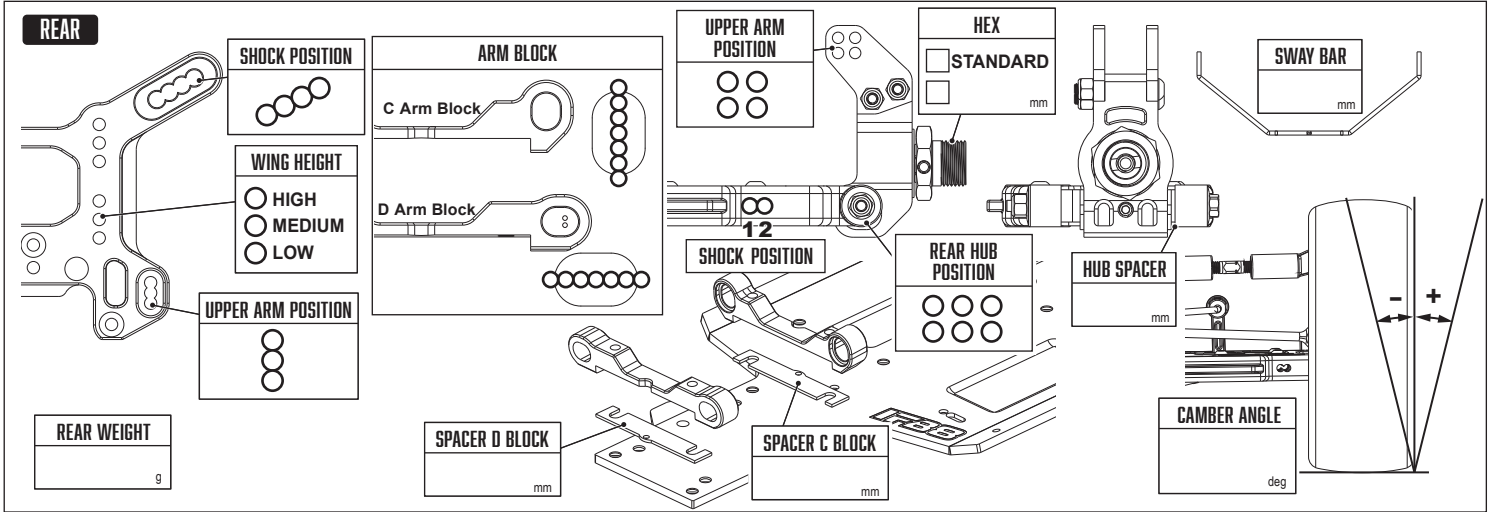
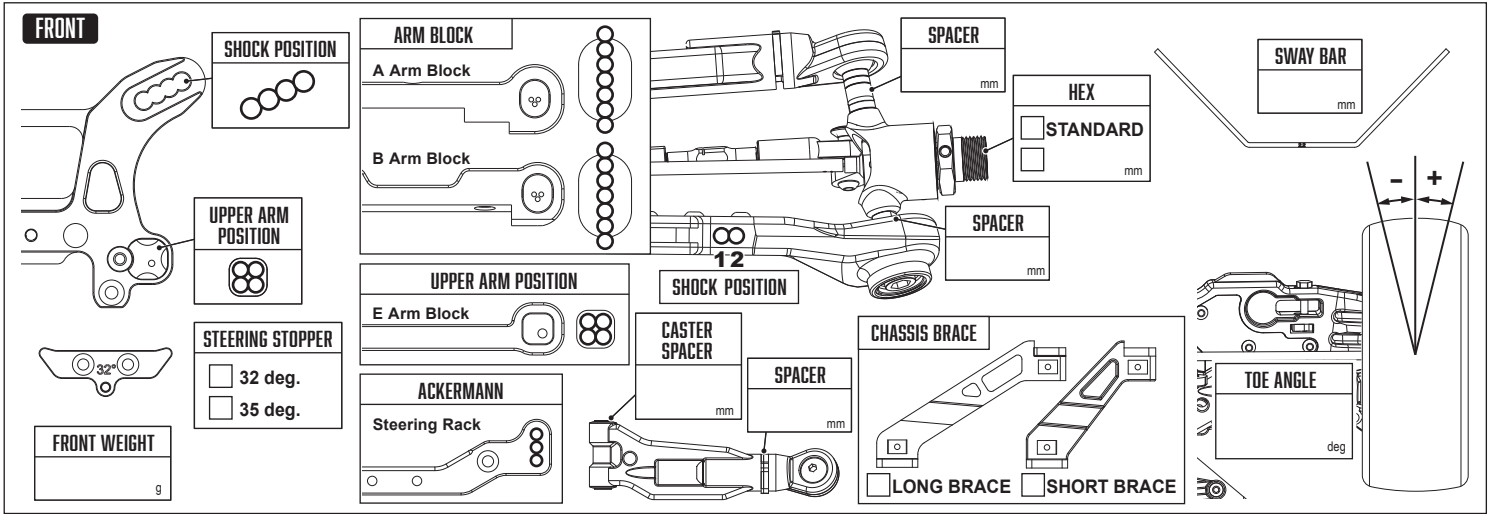

FRONT	SHOCKS	REAR
	OIL	
	SPRING	
	PISTON HOLES	
	MEMBRANE	
	EMULSION	
NOTES:		

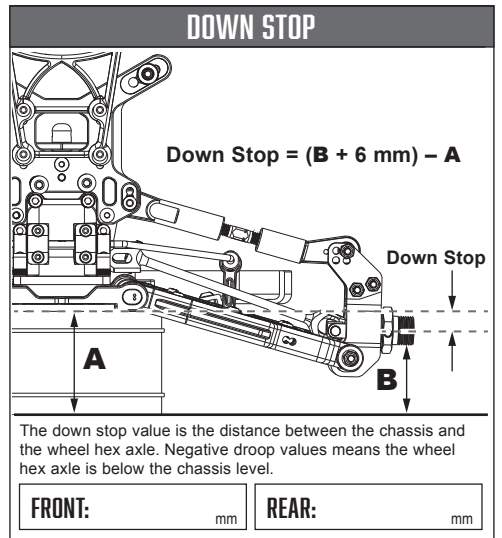
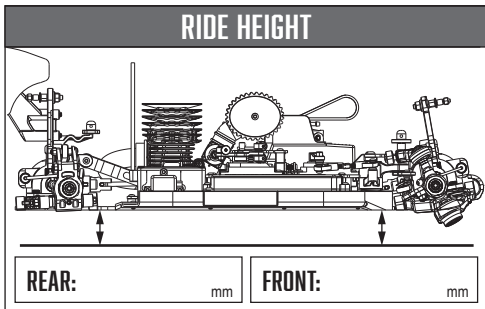

FRONT	DIFFS OIL GRADE	REAR
	CENTER	
NOTES:		

CLUTCH & GEARING

SPUR GEAR: _____ BELL: _____

SHOES: _____

SPRING: _____

NOTES: _____

ENGINE

TYPE: _____

PIPE: _____

MANIFOLD: _____

PLUG: _____

RESTRICTOR: _____

FUEL: _____

BODY & WING

BODY: _____

WING: _____

NOTES: _____

TIRES

TIRE: _____

INSERT: _____

WHEEL: _____

NOTES: _____